

DESIGN NOTES

RS232 Interface Circuits for 3.3V Systems – Design Note 75

Gary Maulding

The rapid, widespread use of 3.3V logic circuits complicates the selection of RS232 interface circuits. The optimum choice of an interface circuit should be based upon several application dependent factors:

- 1) Logic circuitry connected to interface chip
- 2) Power supply voltages available
- 3) Power consumption constraints
- 4) Serial interface environment
- 5) Mouse driving requirements

As Figure 1 illustrates, 5V interface circuits cannot be used to directly connect to 3.3V CMOS logic circuits. The receiver output level will forward bias the logic circuit's input protection diode, causing large current flow. In the worst case the CMOS logic circuit may latch up. Resistor voltage dividers or level shift buffers may be used to prevent forward biasing the CMOS input diode, but an RS232 transceiver designed for 3V logic application prevents this problem without extra components or power dissipation.

Many of today's systems have both 5V and 3V power supplies. In these systems, an RS232 interface chip which uses the 5V supply for charge pump and driver operation and the 3V supply for receiver output levels, provides the best performance. The 5V operation of the charge pump and drivers gives full RS232 output levels and sufficient current drive for operating a serial port mouse. The LT1342, LT1330, and LT1331 are all good RS232 transceiver choices for systems

with both 5V and 3V power. Typical performance waveforms for the LT1342 operating with $V_{CC} = 5V$ and $V_L = 3.3V$ are shown in Figure 2.

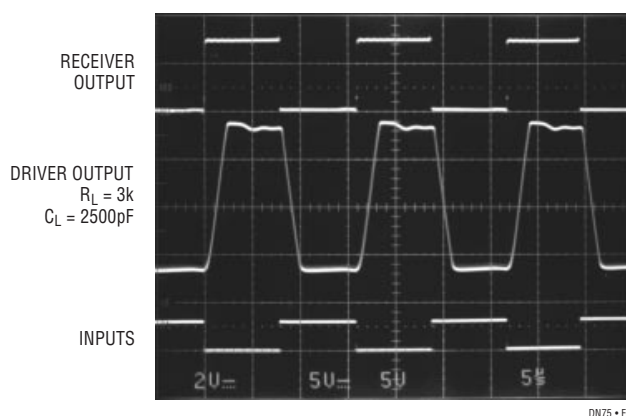

Figure 2. LT1342 Outputs for $V_{CC} = 5V$ and $V_L = 3.3V$

Systems with only a 3V power supply are unable to use 5V powered RS232 interface circuits. Charge pump triplers (or quadruplers) have losses too great for generating RS232 voltage and current levels from a 3.3V supply. The LT1331 and LTC1327 provide solutions for 3V only systems. The LT1331 circuit is usable in both 5V/3V mixed or 3V only systems. When the charge pump is operated from 3V supplies, it powers the driver circuitry to provide RS562 output levels (see Figure 3). RS562 is a newer serial data interface standard than RS232 with lower ($\pm 3.7V$) driver output levels and extended (64k baud vs 20k baud) data rates. RS562 systems and RS232 systems are universally interoperable.

The LTC1327 also provides RS562 output levels from a 3V supply. This circuit features ultra-low 300 μA supply current to maximize battery life. An advanced CMOS process makes this low current operation possible without compromising the rugged overvoltage and ESD protection available on Linear Technology's bipolar interface circuits.

VPP Switcher Drives 3V RS232

When fully RS232 compliant operation or mouse driving is required in a 3V only system, the LT1332 provides the solution. The LT1332 is specifically designed to be used in

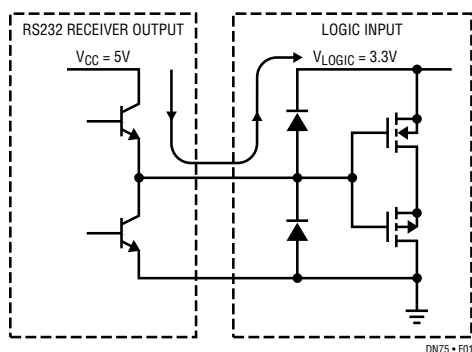

Figure 1. 5V Receiver Forward Biases Logic Input Diode

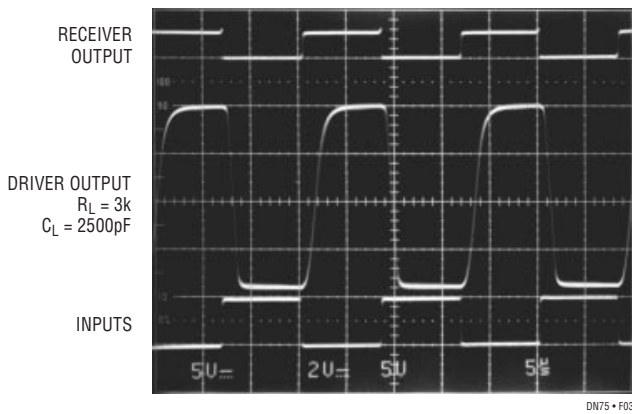

Figure 3. LT1331 Outputs for $V_{CC} = V_L = 3.3V$

conjunction with a micropower switching regulator like the LT1109A. The switcher provides 12V needed for flash memory V_{PP} and the RS232 V^+ . A capacitor from the switcher's drive pin (V_{SW}) to on-chip diodes in the LT1332 form a charge pump to generate the V^- needed for the RS232 drivers. This two chip solution for V_{PP} generation and RS232 interface is a very economical solution in 3V systems where both these needs coexist. The output driver levels of the LT1332 are fully RS232 compliant and capable of driving serial mice, a capability which cannot be met by other 3V operating circuits.

Battery-powered 3V systems can use the RS232 transceiver's SHUTDOWN and Driver Disable controls to maximize battery charge life. These operating mode controls reduce power consumption when communications needs

allow the transceiver to be partially or fully turned off. Keep-alive receivers, available on some transceivers, consume little power ($60\mu A$) while monitoring a data line. When data is detected, the system can be fully powered up to accept and process the incoming data.

ESD Protection

ESD transient protection of data lines is essential for equipment reliability. Traditional protection measures using TransZorbs® and diodes are a large percentage of total interface port component costs. Linear Technology's RS232 and RS562 interface circuits reduce this cost by providing 10kV "Human Body Model" ESD protection on the RS232 data lines without external components. This level of protection is adequate in most applications, but when even higher levels of protection are needed, a simple RC network (see Figure 4) may be used. The RC network raises the ESD protection level to 10kV "Machine Model" discharges at a lower cost than TransZorb® based protection networks.

Table 1. RS232/RS562 Transceivers for 5V/3V and 3V Systems

Part No.	5V/3V RS232	3V RS562	10kV ESD	Comments
LT1342	✓		✓	LT1137A Pin Compatible
LT1330	✓		✓	Low Power Burst Mode™
LT1331	✓	✓	✓	V_{CC} Not Used in SHUTDOWN
LTC1327		✓	✓	300 μA Supply Current
LT1332	3V RS232 Used with LT1109A VPP Generator			

Burst Mode™ is a trademark of Linear Technology Corporation

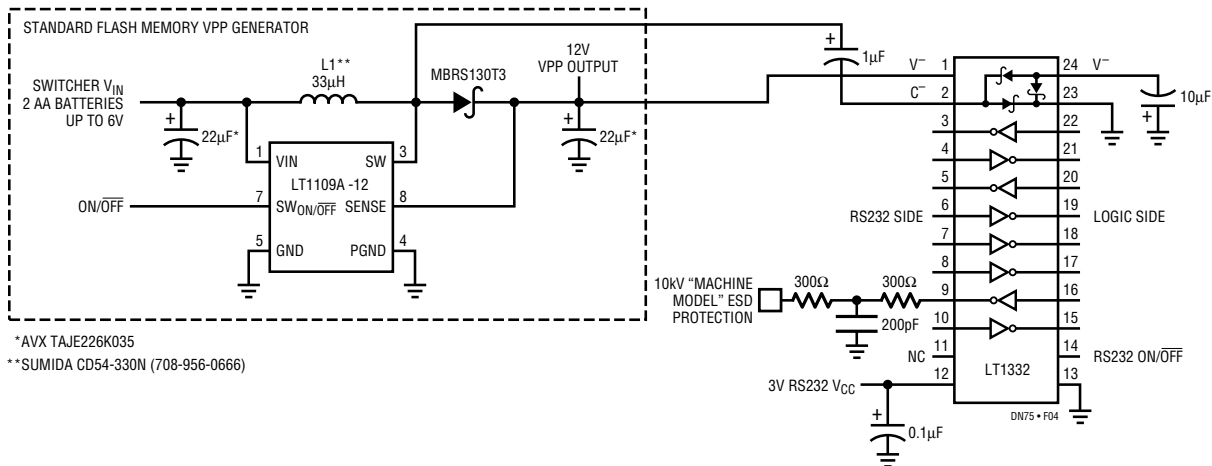

Figure 4. LT1109A-12 and LT1332 Provide VPP Supply and RS232 Interface

TransZorb® is a registered trademark of General Instruments, GSI

For literature on our RS232 Interface Products, call **(800) 637-5545**. For applications help, call (408) 432-1900, Ext. 2452